

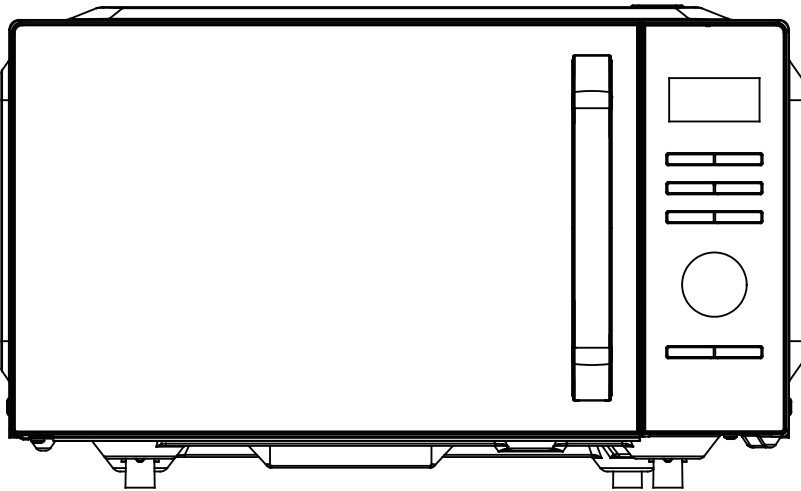

George.
home



GHAMON1251W4G

25L Digital microwave oven

User Guide

230-240V~50HZ, 900W

IMPORTANT: RETAIN FOR FUTURE REFERENCE



About this guide

We've written this manual to help you get the most from your microwave. Please hold on to it for future reference.

WARNINGS:

THIS PRODUCT WAS DESIGNED AND MANUFACTURED TO MEET STRICT QUALITY AND SAFETY STANDARDS. THERE ARE, HOWEVER, SOME OPERATIONAL PRECAUTIONS YOU SHOULD BE AWARE OF. WARNING!--TO REDUCE THE RISK OF BURNS, ELECTRIC SHOCK, FIRE, INJURY TO PERSONS OR EXPOSURE TO EXCESSIVE MICROWAVE ENERGY:

1. Read all instructions before using the appliance and keep for future reference.
2. Use this appliance only for its intended use as described in the manual. Do not use corrosive chemicals or vapors in this appliance. This type of oven is specifically designed to heat or cook food. It is not designed for industrial or laboratory use.
3. Do not operate the oven when empty.
4. Do not operate this appliance if it has a damaged cord or plug, if it is not working properly, or if it has been damaged or dropped. If the supply cord is damaged, it must be replaced by the manufacturer or its service agent or a similarly qualified person in order to avoid a hazard.
5. To reduce the risk of fire in the oven cavity:



- **When heating food in plastic or paper containers, keep an eye on the oven due to the possibility of ignition.**
 - **Remove wire twist-ties from paper or plastic bags before placing bag in oven.**
 - **Do not use the cavity for storage purposes. Do not leave paper products, cooking utensils, or food in the cavity when not in use.**
 - **The microwave oven is intended for heating food and beverages. Drying of clothing and heating of warming pads, slippers, sponges, damp cloth and similar may lead to risk of injury, ignition or fire.**
- 6. WARNING: Liquid or other food must not be heated in sealed containers since they are liable to explode.**
 - 7. Microwave heating of beverage can result in delayed eruptive boiling, therefore care has to be taken when handle the container.**
 - 8. Do not fry food in the oven. Hot oil can damage oven parts and utensils and even result in skin burns.**
 - 9. Eggs in their shell and whole hard-boiled eggs should not be heated in microwave ovens since they may explode, even after microwave heating has ended.**
 - 10. Pierce foods with heavy skins such as potatoes, whole squashes, apples and chestnuts before cooking.**
 - 11. The contents of feeding bottles and baby food jars should be stirred or shaken and the temperature should be checked before consumption in order to avoid burns.**
 - 12. Cooking utensils may become hot because of heat transferred from the heated food. Potholders or oven gloves may be needed to handle the utensil.**
 - 13. Utensils should be checked to ensure that they are suitable for use in microwave oven.**



14. **WARNING:** It is hazardous for anyone other than a trained person to carry out any service or repair operation which involves the removal of any cover which gives protection against exposure to microwave energy.
15. This appliance is a Group 2 Class B equipment. Group 2 equipment: group 2 contains all ISM RF equipment in which radio-frequency energy in the frequency range 9 kHz to 400 GHz is intentionally generated and used or only used locally, in the form of electromagnetic radiation, inductive and/or capacitive coupling, for the treatment of material, for inspection/analysis purposes, or for transfer of electromagnetic energy. Class B equipment is equipment suitable for use in locations in residential environments and in establishments directly connected to a low voltage power supply network which supplies buildings used for domestic purposes.
16. The microwave oven is only to be used freestanding.
17. **WARNING:** Do not install microwave oven over an oven or hob or other heat-producing appliance.
18. The microwave oven shall not be placed in a cabinet.
19. The door or the outer surface may get hot when the appliance is operating.
20. **Warning:** Accessible parts may become hot during use. Young children should be kept away.
21. During use the appliance becomes hot. Care should be taken to avoid touching any parts inside the microwave oven.
22. The temperature of accessible surfaces may be high when the appliance is operating.
23. The appliance shall be placed against a wall.
24. **WARNING:** If the door or door seals are damaged, the oven must not be operated until it has been repaired by a competent person.





- 25. This appliance is not intended to be operated by means of an external timer or separate remote-control system.**
- 26. The microwave oven is for household use only and not for commercial use.**
- 27. Please secure the turn table before you move the appliance to avoid damage.**
- 28. The microwave oven is intended for defrosting, cooking and steaming of food only.**
- 29. Use gloves if you remove any heated food.**
- 30. Caution! Steam will escape, when opening lids or wrapping foil.**
- 31. This appliance can be used by children aged from 8 years and above and persons with reduced physical, sensory or mental capabilities or lack of experience and knowledge if they have been given supervision or instruction concerning use of the appliance in a safe way and understand the hazards involved. Children shall not play with the appliance. Cleaning and user maintenance shall not be made by children without supervision.**
- 32. If smoke is emitted, switch off or unplug the appliance and keep the door closed in order to stifle any flames.**
- 33. Keep the waveguard cover clean at all times and wipe the interior with a damp cloth after each use. If you leave grease or fat it may overheat, smoke or catch fire.**
- 34. Do not use attachments not recommended by the manufacturer.**
- 35. Do not leave the microwave unattended when in use.**
- 36. Unplug when not in use and before cleaning.**
- 37. The appliance shall not be cleaned with a steam cleaner.**



38. The door seals are located around the window and on the inside of the door. The seals are not airtight, but although no microwaves are released it is normal for a small amount of air or steam to escape when the microwave is in use.
39. Please don't dismantle. If a fault occurs have the microwave inspected in a qualified repair shop or return to us at ASDA.
40. ASDA does not recommend allowing children to operate this appliance.
 - The oven should be cleaned regularly and any food deposits removed.
 - Failure to maintain the oven in a clean condition could lead to deterioration of the surface that could adversely affect the life of the appliance and possibly result in a hazardous situation.
 - Metallic containers for food and beverages are not allowed during microwave cooking.

You should have

Microwave oven, glass tray, turn table support, bake plate and Air Fry kit

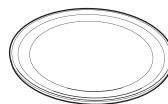
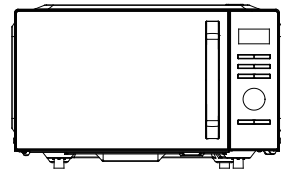



GROUNDING INSTRUCTIONS

This appliance must be grounded. This oven is equipped with a cord having a grounding wire with a grounding plug. It must be plugged into a wall receptacle that is properly installed and grounded. In the event of an electrical short circuit, grounding reduces risk of electric shock by providing an escape wire for the electric current. It is recommended that a separate circuit serving only the oven be provided. Using a high voltage is dangerous and may result in a fire or other accident causing oven damage.

WARNING!--Improper use of the grounding plug can result in a risk of electric shock.

Note:

If you have any questions about the grounding or electrical instructions, consult a qualified electrician or service person.

Neither the manufacturer nor the dealer can accept any liability for damage to the oven or personal injury resulting from failure to observe the electrical connection procedures.

The wires in this cable main are colored in accordance with the following code:

Green and Yellow = EARTH

Blue = NEUTRAL

Brown = LIVE



RADIO INTERFERENCE

Operation of the microwave oven can cause interference to your radio, TV, or similar equipment. When there is interference, it may be reduced or eliminated by taking the following measures:

1. Clean door and sealing surface of the oven.
2. Reorient the receiving antenna of radio or television.
3. Relocate the microwave oven with respect to the receiver.
4. Move the microwave oven away from the receiver.
5. Plug the microwave oven into a different outlet so that microwave oven and receiver are on different branch circuits.

BEFORE CALLING FOR SERVICE

Before asking for service, please check each item below:

- Check to ensure the oven is plugged in securely. If not, remove the plug from the outlet, wait 10 seconds, and plug it in again securely.
- Check for a blown circuit fuse or a tripped main circuit breaker. If these seem to be operating properly, test the outlet with another appliance.
- Check to ensure the control panel is programmed correctly and the timer is set.
- Check to ensure the door is securely closed, engaging the door lock system. If the door is not properly closed, the microwave energy will not flow inside.

IF NONE OF THE ABOVE RECTIFIES THE SITUATION, THEN CONTACT A QUALIFIED TECHNICIAN. DO NOT TRY TO ADJUST OR REPAIR THE OVEN YOURSELF.



COOKING TECHNIQUES

1. Arrange food carefully. Place thickest areas towards outside of dish.
2. Watch cooking time. Cook for the shortest amount of time indicated and add more as needed. Food severely overcooked can smoke or ignite.
3. Cover foods while cooking. Covers prevent spattering and help foods to cook evenly.
4. Turn foods over once during microwave cooking to speed cooking of such foods as chicken and hamburgers. Large items like roasts must be turned over at least once.
5. Rearrange foods such as meatballs halfway through cooking both from top to bottom and from the center of the dish to the outside.

COOKING UTENSILS GUIDE

1. Microwave cannot penetrate metal. Only use utensils that are suitable for use in microwave ovens. Metallic containers for food and beverages are not allowed during microwave cooking. This requirement is not applicable if the manufacturer specifies size and shape of metallic containers suitable for microwave cooking.
2. Microwave cannot penetrate metal, so metal utensils or dishes with metallic trim should not be used.
3. Do not use recycled paper products when microwave cooking, as they may contain small metal fragments which may cause sparks and/or fires.
4. Round /oval dishes rather than square/oblong ones are recommend, as food in corners tends to overcook.
5. Narrow strips of aluminum foil may be used to prevent overcooking of exposed areas. But be careful don' t use too much and keep a distance of 1 inch (2.54cm) between foil and cavity.



The list below is a general guide to help you select the correct utensils.

Cookware	Microwave	Grill	Convection	Combination*
Heat-Resistant Glass	Yes	Yes	Yes	Yes
Non Heat-Resistant Glass	No	No	No	No
Heat-Resistant Ceramics	Yes	Yes	Yes	Yes
Microwave-Safe Plastic Dish	Yes	No	No	No
Kitchen Paper	Yes	No	No	No
Metal Tray	No	Yes	Yes	No
Metal Rack	No	Yes	Yes	No
Aluminum Foil & Foil Container	No	Yes	Yes	No

* Combination: applicable for both "microwave +grill", and "microwave+convection" cooking.





How to...

...recognise the parts of your microwave

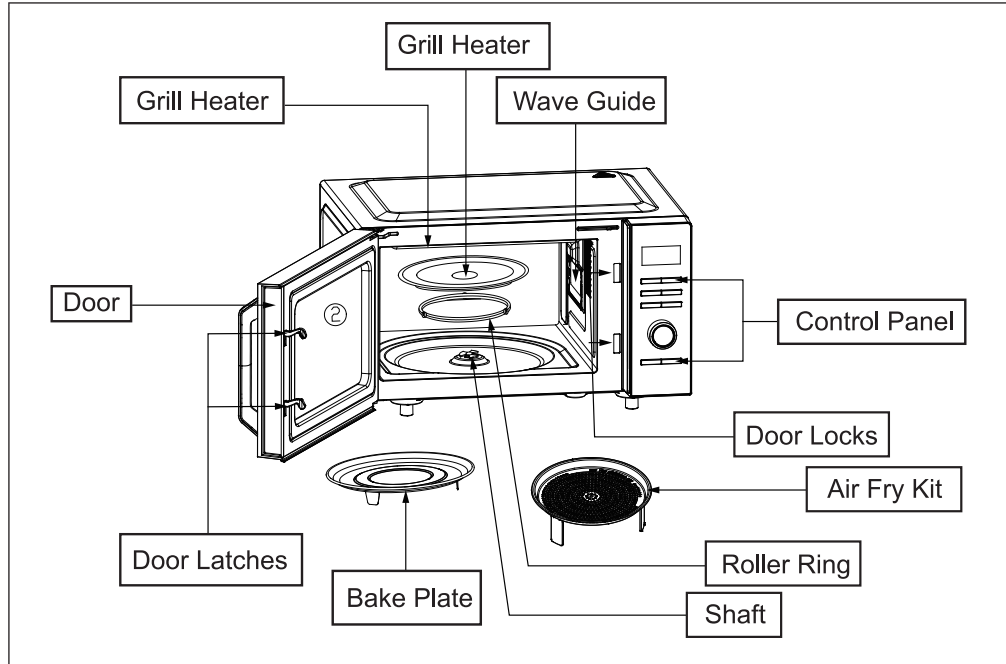

How to...

...assemble your microwave

1. Remove any tape and place the turntable support in the centre of the recess on the floor of the microwave.
2. Place the glass tray onto the turntable support, aligned with the turntable shaft.

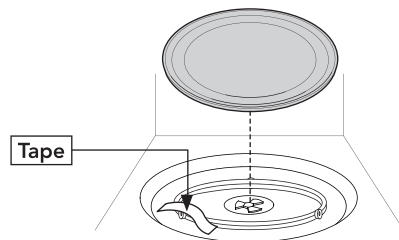



How to...

...recognise the microwave control panel

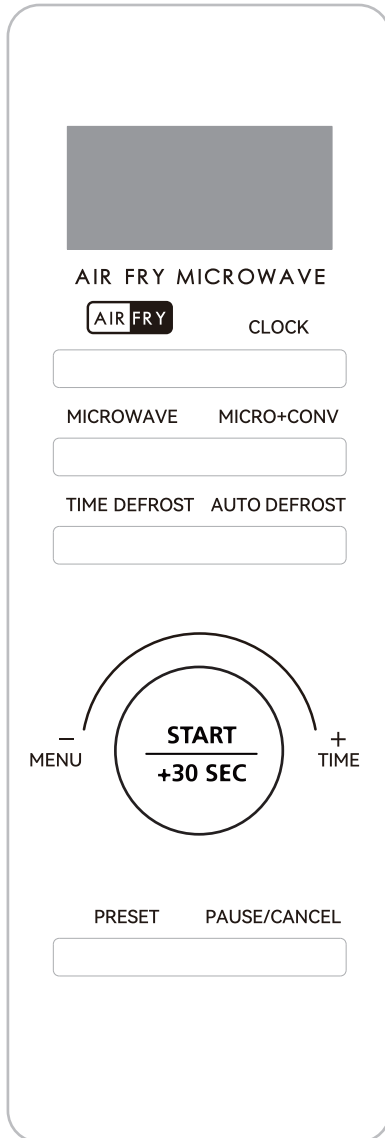

- **DISPLAY**

Time, power and indicators are displayed.

- **AIR FRY**

Use the air fry function to cook food.

- **CLOCK**

Press to set clock time.

- **MICROWAVE**

Press to select microwave power level.

- **MICRO+CONV**

Press to set microwave and convection combination cooking programs.

- **TIME DEFROST**

Press to defrost food based on time.

- **AUTO DEFROST**

Press to defrost food based on weight.

- **MENU/TIME (dial)**

Turn the dial to set time, food weight or servings.

Turn the dial to select auto cooking menus.

- **START/+30 SEC. (the dial)**

Press the dial to start cooking programs.

Press the dial to set express cooking program.

- **PRESET**

Use to set the oven to start-up at a later time.

- **PAUSE/CANCEL**

Press once to temporarily stop cooking, or twice to cancel cooking altogether.

It is also used to set child lock.





How to...

...use your microwave

Please note

Do not use metal pans or items with a metal handle or trim (including wire twist-ties) or melamine dishes (as they contain material that absorbs microwave energy and may cause dishes to crack or burn). All cookware should be suitable for microwave use and no containers with restricted openings (e.g. bottles) should be used. If baby bottles are heated, the teat should not be left on.

1. Slot the plug into the mains socket and switch the power on.

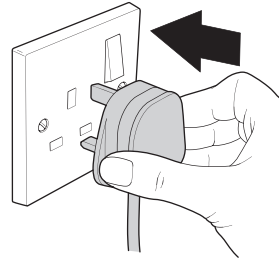

2. Place desired food to cook or defrost into a microwave-safe container, cover with a suitable cover (e.g. microwave-safe cling film). Always pierce coverings with a fork to allow the steam to escape.
3. Pull the door handle to open the microwave door and place the food centrally on the glass plate in the microwave. Ensure multiple items are equally spaced.

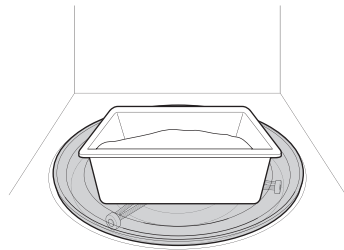

4. Close the door and turn the power dial to the required level. Always check the food packaging for microwave guidelines specific to that product.

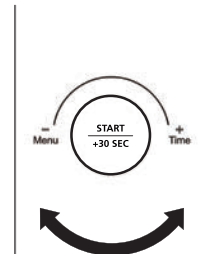



5. Turn the timer dial to the desired menu and time (up to 95 minutes).

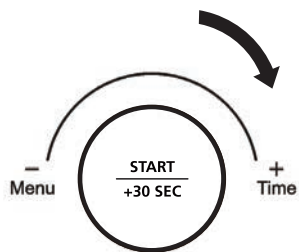

6. Once the timer has been set the microwave will automatically turn on and start cooking.

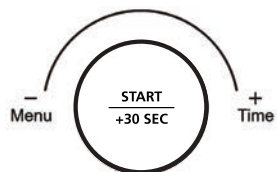

7. After the food has finished cooking the microwave will ding and turn off.

Leave the microwave for 30 seconds to 1 minute before opening the door, and removing the food with oven gloves.

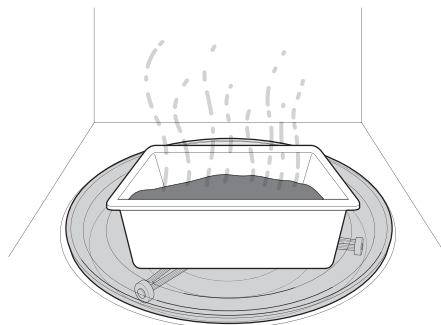



Setting Clock Time

This is a 24- or 12- hour clock. You can choose to set the clock time in 24- or 12- hour by pressing CLOCK button in standby mode.

1. In standby mode, press CLOCK button repeatedly to choose 24- or 12-hour clock.
2. Turn MENU/TIME dial to set hour digit.
3. Press CLOCK button once.
4. Turn MENU/TIME to set minute digit.
5. Press CLOCK button once to confirm.

NOTE: During cooking, you can check the current clock time by pressing CLOCK button.

Express Cooking

Use this feature to program the oven to microwave food at 100% power conveniently. In standby mode, press START/+30 SEC.button once (Default cooking time is 30 seconds), the oven will start working automatically. During cooking, you can add cooking time by pressing START/+30 SEC.button, each press to increase 30 seconds, and up to 10 minutes.



Microwave Cooking

1. In standby mode, press MICROWAVE button repeatedly to set power level.
2. Turn MENU/TIME dial to set cooking time. The longest time is 95 minutes.
3. Press START/+30 SEC. button to start.

Press MICROWAVE button repeatedly to set power level:

Press MICROWAVE	Power (Display)	Press MICROWAVE	Power (Display)
Once	100% (P100)	7 times	40% (P-40)
Twice	90% (P-90)	8 times	30% (P-30)
3 times	80% (P-80)	9 times	20% (P-20)
4 times	70% (P-70)	10 times	10% (P-10)
5 times	60% (P-60)	11 times	0% (P-00)
6 times	50% (P-50)		

NOTE: If you want to cook at full power level, directly turn MENU/TIME dial clockwise to set cooking time, then press START/+30 SEC. button to start. During cooking, you can check the cooking power level by pressing MICROWAVE button.





AIR FRY

This oven can be programmed for ten different cooking temperatures (200 °C → 210 °C → 220 °C → 230 °C → 110 °C → 120 °C → 130 °C → 140 °C → 150 °C → 160 °C → 170 °C → 180 °C → 190 °C). The cooking time ranges from 10 seconds to 95 minutes.

To preheat and cook with air fry:

Your oven can be programmed to combine preheating and air fry cooking operations.

1. In standby mode, press AIR FRY button repeatedly to select temperature.
2. Press START/+30 SEC. button once to confirm. Beeps will sound when the designated temperature is reached.
3. Open the door or press PAUSE/CANCEL button once, then place container of food at the center of the turntable.
4. Turn MENU/TIME dial to set cooking time.
5. Press START/+30 SEC. button to start.

To cook with air fry:

1. In standby mode, press AIR FRY button repeatedly to select temperature.
2. Turn MENU/TIME dial to set cooking time.
3. Press START/+30 SEC. button to start.



Microwave+Convection

This oven has four pre-programmed settings that make it easy to cook with both convection heat and microwave automatically. Press MICRO+CONVECTION button repeatedly to program convection temperature 200°C→170°C →140°C→110°C.

1. In standby mode, press MICRO+CONVECTION button repeatedly to select cooking temperature.
2. Turn MENU/TIME dial to set cooking time. The longest time is 95 minutes.
3. Press START/+30 SEC. button to confirm.

TIME DEFROST

1. In standby mode, press TIME DEFROST button once.
2. Turn MENU/TIME dial to set defrosting time. The time ranges from 10 seconds to 95 minutes.
3. Press START/+30 SEC. button to confirm.

NOTE: During defrosting, the system will pause and sound to remind user to turn food over, and then press START/+30 SEC. button to resume.

AUTO COOK

For the following food or cooking mode, it is not necessary to program the cooking time and power. It is sufficient to indicate the type of food that you want to cook as well as the weight or servings of this food.



1. In standby mode, turn MENU/TIME dial anti-clockwise once, the display shows "A-01", then continue to turn the dial to select another food code.
2. Turn MENU/TIME dial to select food weight or servings.
3. Press START/+30 SEC. button to start.

Auto cook menus

Code	Menu	Mode	Note
A-01	Milk/Coffee (200 ml/cup, 1-3 cups)	Microwave	<p>1. For Milk/Coffee and Potato, the display screen will not show the icon "g".</p> <p>2. For items A-07 ~ A-09, during cooking, you need to turn food over.</p> <p>3. The result of auto cooking depends on factors such as fluctuation of voltage, the shape and size of food, your personal preference as to the doneness of certain foods and even how well you happen to place food in the oven. If you find the result at any rate not quite satisfactory, please adjust the cooking time a little bit accordingly.</p>
A-02	Potato (230±10 g/serving, 1-2 servings)	Microwave	
A-03	Rice (150-600 g)	Microwave	
A-04	Spaghetti (100 g, 200 g, 300 g)	Microwave	
A-05	Auto Reheat (200-800 g)	Microwave	
A-06	Fish (200-600 g)	Combination	
A-07	Beef/Mutton (200-600 g)	Combination	
A-08	Skewered Meat (100-500 g)	Combination	
A-09	Roast Chicken (800-1400 g)	Combination	
A-10	Cake (475 g)	Convection	
A-11	Onion Rings (200 g)	Convection	
A-12	Chicken Drumsticks (200-600 g)	Convection	
A-13	Chicken Wings (200-500 g)	Convection	
A-14	Chicken Nuggets (150-300 g)	Convection	
A-15	Popcorn Chicken (250-400 g)	Convection	
A-16	French Fries (250 g)	Convection	
A-17	Mozzarella Sticks (200-450 g)	Convection	



Child Lock

Use to prevent unsupervised operation of the oven by children.
To set: In standby mode, press and hold PAUSE/CANCEL button for more than 3 seconds, a beep will sound and the display will show "Loc" for 5 seconds, the oven will auto enter child lock mode. In the lock state, all buttons are disabled.
To cancel: Press and hold PAUSE/CANCEL button for more than 3 seconds, a beep will sound and the "Loc" will disappear.



How to...

...clean your microwave

Make sure the microwave is disconnected from the power and is completely cool. Failure to keep the microwave clean can lead to deterioration in the interior that could affect the life of the appliance and result in a hazardous condition.

1. When food or liquids stick to the microwave walls wipe clean with a damp cloth (do not use harsh detergents or abrasives).
2. You can clean the outside of the oven with a damp cloth and dry with a soft dry cloth. Don't allow water to seep into the ventilation openings.
3. Wipe the door and window on both sides regularly along with the door seals and adjacent parts with a damp cloth to remove spills or spatters. Do not use abrasive cleaners.
4. The waveguide cover is on the right side of the oven - this is where microwave pass through to cook your food. **NEVER** use the microwave without the waveguide cover. If it is damage please contact the technical helpline for a replacement. It must be kept clean at all times by wiping with a mild detergent and water, then allowing to dry.
5. Do not allow the control panel to become wet. Clean with a damp cloth and dry thoroughly.
6. If steam builds inside or around the microwave door, wipe away with a damp cloth.
7. If the inside of the microwave smells, mix the juice and skin of a lemon with some water in a microwavable bowl. Place in the microwave and heat for 3 minutes on full power, then wipe the inside of the microwave thoroughly with a dry cloth.
8. Regularly clean the turntable support and oven floor by wiping the bottom of the oven with a mild detergent and water, then drying with a cloth. The turntable can be washed in warm soapy water, then dried thoroughly before placing back inside the microwave. Always make sure it is fitted back in correctly.



How to...

...solve common problems

Problem	What to do
If the microwave doesn't work.	<ol style="list-style-type: none"> 1. Ensure it is plugged in securely. 2. Check the mains fuse has not been tripped (if it has, reset the fuse). 3. See if another appliance works when plugged into the same socket (if it doesn't, the socket may be faulty). 4. If the socket works, replace the fuse.
If the microwave will not heat food:	<ol style="list-style-type: none"> 1. Check the timer has not been set. 2. Ensure the door is securely closed (as a safety feature, if the door is not fully shut the microwave will not operate).

SPECIFICATIONS

Power Supply	230-240V/50Hz
Power Consumption (Microwave)	1400W
Power Consumption (Convection)	1500W
Rated Microwave Power Output	900W
Operation Frequency	2450MHz
Outside Dimensions	287mm(H)x493mm(W)x440MM(D)
Oven Cavity Dimensions	197MM(H)x340mm(W)x360mm(D)
Oven Capacity	25Litres
Net Weight	Approx. 17.6kg



How to...

...change the fuse

1. Only use a 13 amp fuse.
2. To change the fuse, place a screwdriver into the recess of the plug cover and pull the fuse holder upward until it's free.
3. Slide the fuse out and pop in the replacement.
4. Slot the fuse holder back into the recess and push down until it locks into place.

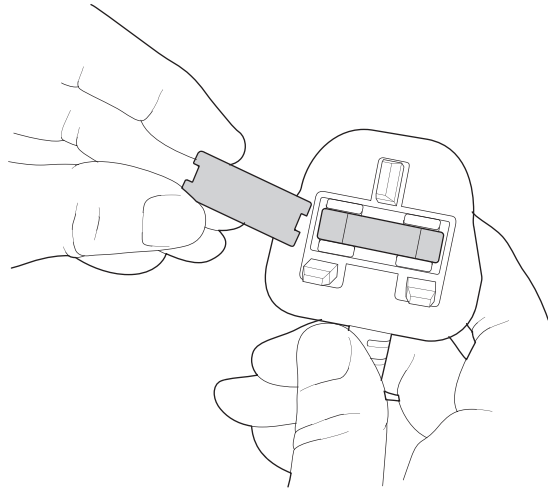
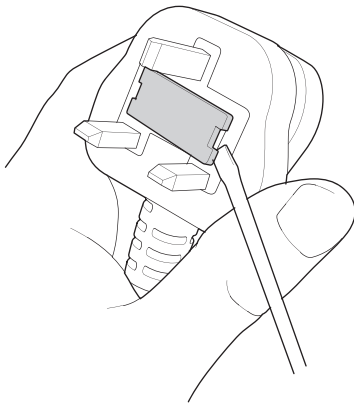



Notes...





If for any reason you're not completely satisfied with our product, return it within 100 days with your proof of purchase, and we'll give you an exchange or a refund.

UK Mainland stores only.

Excludes franchises.

The guarantee excludes flat pack furniture, which can't be returned if it has been partly or fully assembled unless faulty or mis-described.

Also excludes mattresses, which can't be returned for hygiene reasons once used, unless faulty or mis-described.



www.GEORGE.com

We have a wide range of accessories and other products that can be ordered direct to your door.

For PDF copy of this manual please scan QR code and search for model number

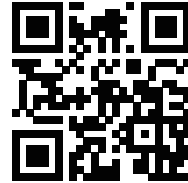

ASDA
technica support
0333 600 7 700

Customer services information

If you have any problems, need more information or spare parts, or even just some advice on your product, then don't hesitate to contact customer services at the telephone number or address shown opposite. N.B. When calling or writing please have your product site code handy.

Call

0800 952 0101

Write

ASDA, Leeds LS11 5AD.

Product name:	GHAMON1251W4G 25L Digital microwave oven
Product site code:	15A.06.24.138





To qualify for the 2 year warranty the appliance must have been used according to the manufacturer's instructions. For example kettles should have been regularly de-scaled.

If your appliance stops working or develops a fault then return it to your nearest store and we will happily replace or refund the item, with exception of the below exclusions:

EXCLUSIONS

ASDA shall not be liable to replace goods under the terms of the warranty where:

1. The fault has been caused or is attributable to accidental use, misuse, negligent use or use contrary to the user manual's recommendations or where the fault has been caused by power surges or damage caused in transit.
2. The appliance has been used on a voltage supply other than that described on the product rating label.
3. Repairs have been attempted by persons other than our service staff (or authorised dealer).
4. Where the appliance has been used for hire purposes or non-domestic use.
5. ASDA are not liable to carry out any type of servicing work, under the warranty.

This warranty does not confer any rights other than those expressly set out above and does not cover any claims for consequential loss or damage. This warranty is offered as an additional benefit and does not affect your statutory rights as a consumer.

If for any reason this item is replaced during the 2 year warranty period, the warranty on the new item will be calculated from original purchase date. It is vital to retain your original proof of purchase to indicate the date of initial purchase.

Copyright

© 2024 ASDA Stores Limited.
All other trademarks appearing herein are the property of their representative owners.
Specifications are subject to change without notice.

Manufactured for:
ASDA, Leeds LS11 5AD/
ASDA, Antrim BT41 4GY.

Disposal

This symbol on the product or in the instructions means that your electrical and electronic equipment should be disposed at the end of its life separately from your household waste. There are separate collection systems for recycling in the UK.

For more information, please contact the local authority or your retailer where you purchased the product.

